

Pack Contents:

1. 1x Escutcheon base
2. 1x Escutcheon
3. 2x Fixing screws

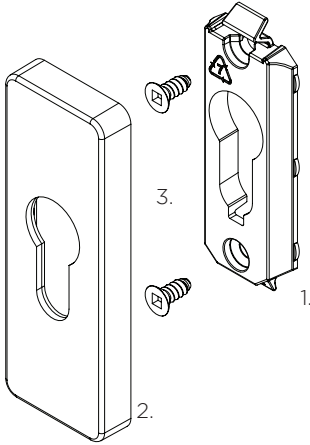

1. Door Preparation

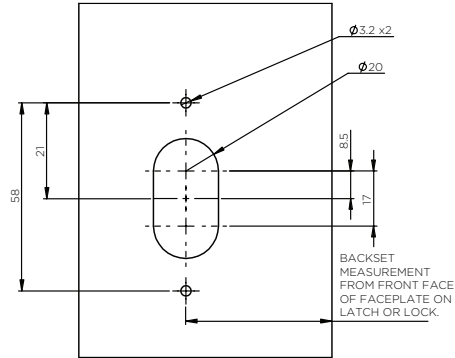

2. Base fitment

Fit the escutcheon base using 2x fixing screws provided.

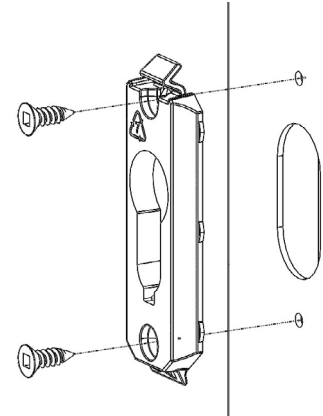

3. Escutcheon fitment

Mount escutcheon on to the base at the bottom.

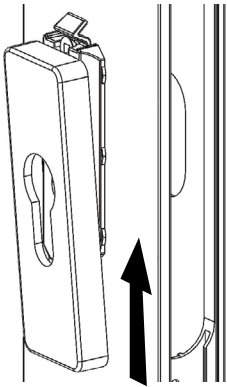

4. Escutcheon fitment cont.

Press fit the escutcheon on to the base top snap clip.

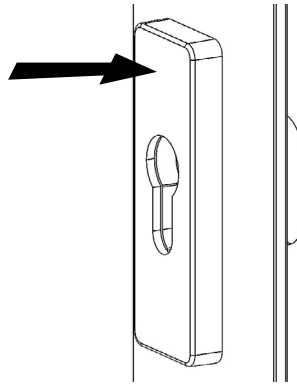

5. Escutcheon fitment cont.

Escutcheon mounted cross section

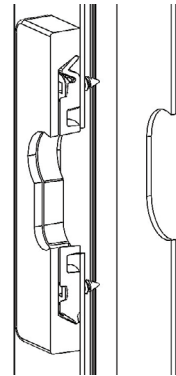

Installed product

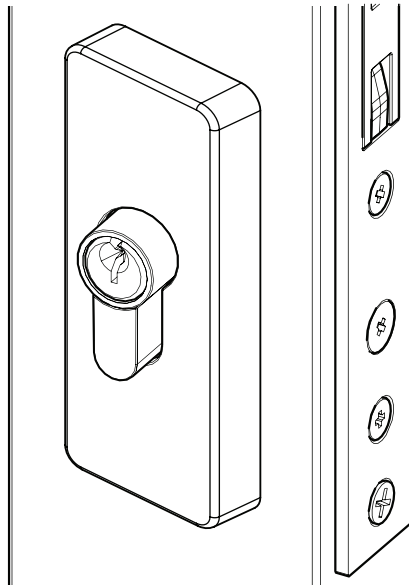

6. Escutcheon removal

Use a screw driver to push the escutcheon down to release it from the bottom of the base.

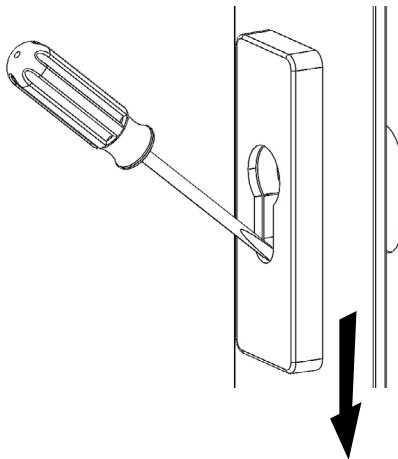

7. Escutcheon removal

Once released, pull the escutcheon away from the door.

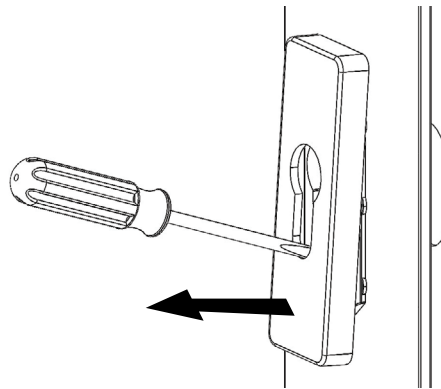

8. Escutcheon removal

Remove the escutcheon.

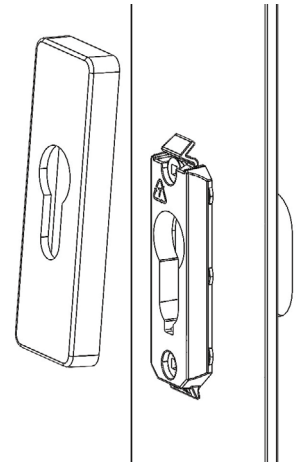

CARE AND MAINTENANCE

Installation

The product must be installed according to the instructions included in the product packaging and the door should be apertured according to the door "cut-out" dimensions and tolerances shown.

Prior to fitting ensure that:

Doors stored on site are stored in a clean dry area free from cement, lime, paint, acid etc.

During fitting of the lock ensure that:

- No metal swarf or other contaminants enter the lock body.
- The fixing screws do not damage the product finish.
- Ensure that screws are not overtightened. Especially when using power tools.

After installation of the door ensure that:

- The door is correctly adjusted with the correct clearances.
- The lock engages the strike plate correctly.
- The door is protected from building fall-out such as wet plaster, mortar, paint and welding splatter.

If the door becomes contaminated:

- Do not paint the lock body or faceplate.
- Remove wet plaster, cement, mortar and other droppings immediately, using ample clean water and a sponge or rag, to avoid permanent staining or scratching of the product finish.
- If removal is delayed and scraping becomes necessary the surface finish may suffer.

Stainless Steel Care

Tea staining (brown discolouration on the surface of stainless steel) is a relatively common occurrence in coastal and marine environments or when in contact with water containing significant chlorides. High temperatures, humidity, wind and salt deposits from sea spray are all contributing factors to this staining that generally becomes progressively worse closer to the coast. Aesthetically unpleasant, tea staining does not affect the structural integrity, or longevity of the material. The following is a list of common conditions that cause corrosion or discolouration of stainless steel and should be avoided:

- Chloride containing cleansers - this includes bleach and any bleach containing cleaners.
- Muriatic acid (hydrochloric acid) - commonly used to clean up after tile / concrete installation.
- Concentrated soap residue - chemical additives will cause discoloration.
- Water with high iron content - can leave a rusty residue, especially if allowed to drip continuously.

- Contact with iron materials - including steel wool, machining chips/swarf, and iron residue/dust from installation or cleaning of other steel products.
- Trapped moisture between the product and another object.
- Salts - contain chlorides.

Stainless Steel Maintenance

Any discolouration or corrosion should be removed as soon as possible or permanent discolouration and pitting of the surface could occur. Usually, the product can be restored to its original condition. Most of the discolouration can be removed with a mild cleaner (Ajax Powder, warm water mixture with baking powder) or stainless steel cleaners (Goddard's Stainless Steel Cleaner, CRC Xtra Shine etc.) and a Scotchbrite pad. The surface should then be thoroughly rinsed with clear water and dried with a soft cloth. With proper maintenance, stainless steel will maintain its lustre and appearance indefinitely. If the environmental conditions cannot be removed (i.e. salt or chlorine in the air), the item should be cleaned often and rinsed with clear water to prevent permanent damage to the stainless steel. In coastal or marine environments we recommend applying a light application of corrosion preventative such as CRC Marine 66 or Inox for Marine, to all surfaces and using a dry cloth to remove excess. When using lubricant or corrosion protection compounds, be careful to avoid the adjacent surfaces and always follow the manufacturer's instructions.

Frequency

As a guide, if a window or door requires washing, then wash the hardware; however we recommend for marine and industrial environments, a minimum period of every 3 months and 6 months for general environments.

Warranty

The visual appearance and preservation of the surface finish of Austral Lock stainless steel products is the responsibility of the end user or consumer to follow the above 'care and maintenance' recommendations. Austral Lock's warranty does not cover the effects of tea staining on stainless steel products.

PDAU006



ALLEGION

1800 098 094
info.au@allegion.com
ausloc.com