

Pack contents:

- 1 x Flush pull handle (preassembled)
- 1 x Grub screw (preassembled)

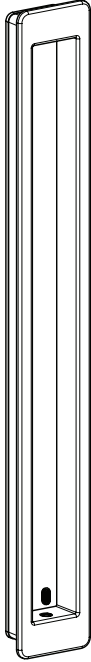

1. Door preparation

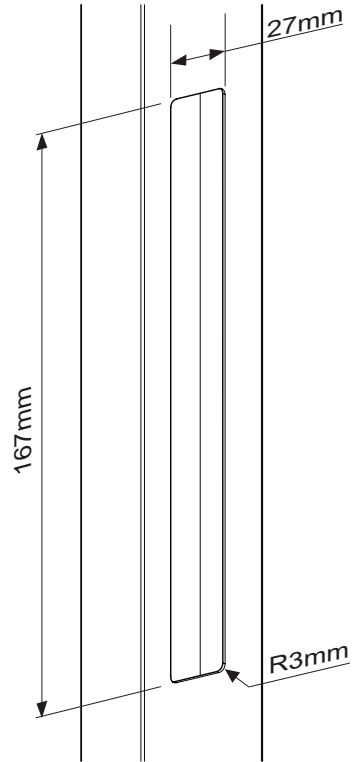

2. Handle preparation

- Adjust grub screw with an Allen key as shown to allow the handle to be inserted into the cut-out

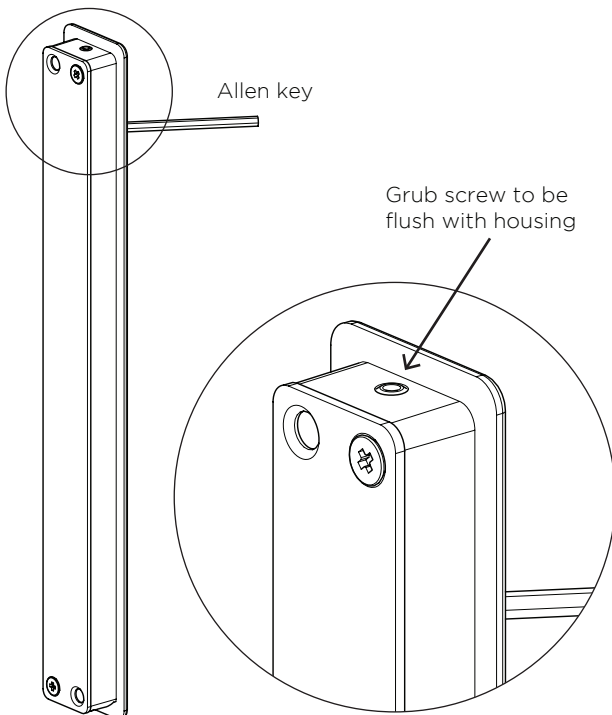

3. Installation

- Install the notched end into the cut-out first
- Swing the top into the cut-out and tighten the grub screw to secure

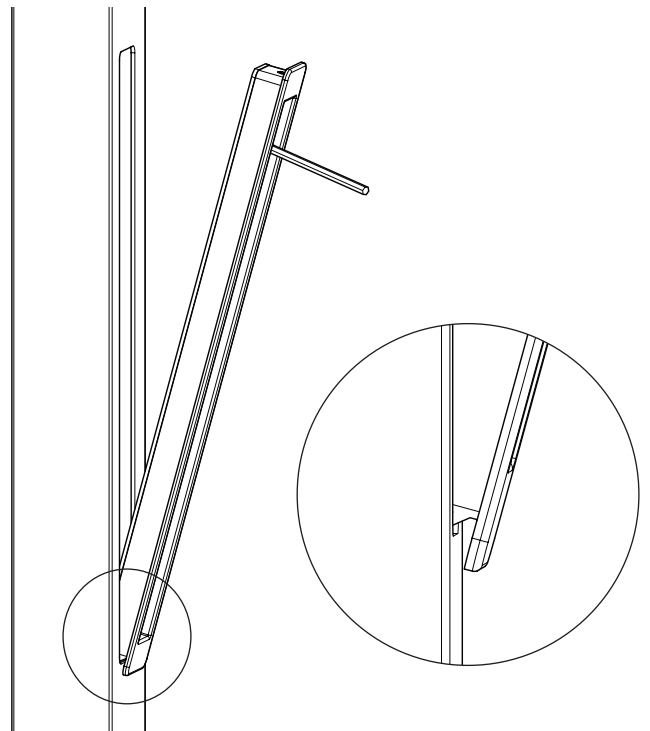

4. Product overview

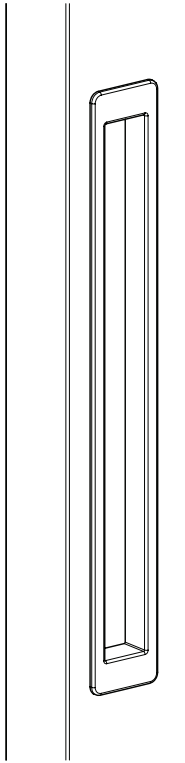

CARE & MAINTENANCE

Installation

The product must be installed according to the instructions included in the product packaging and the door should be apertured according to the door “cut-out” dimensions and tolerances shown.

Prior to fitting ensure that:

Doors stored on site are stored in a clean dry area free from cement, lime, paint, acid etc.

During fitting of the lock ensure that:

- No metal swarf or other contaminants enter the lock body.
- The fixing screws do not damage the product finish.
- *Ensure that screws are not overtightened. Especially when using power tools*

After installation of the door ensure that:

- The door is correctly adjusted with the correct clearances.
- The lock engages the strike plate correctly.
- The door is protected from building fall-out such as wet plaster, mortar, paint and welding splatter.

If the door becomes contaminated:

- Do not paint the lock body or faceplate.
- Remove wet plaster, cement, mortar and other droppings immediately, using ample clean water and a sponge or rag, to avoid permanent staining or scratching of the product finish.
- If removal is delayed and scraping becomes necessary the surface finish may suffer.

Maintenance

- Annually inspect the door to confirm that the door operates with the correct clearances, closes and opens without obstruction and confirm that the lock beak slides easily into the strike plate aperture when the door is closed - adjust the door if necessary.
- Annually check that when the door is closed, the lock can be locked by key and by the snib lever.
- Quarterly wipe the strike plates with a soapy rag to remove built up debris and to lubricate the strike plate.

NOTE : The lock assembly has been lubricated for life, and should not be disassembled by the user.

Cleaning Powder Coatings

Every six months, powder coated surfaces should be cleaned to protect the finish. However, in areas where pollutants are more prevalent, especially in coastal or industrial regions, cleaning should be carried out every two to three months. To clean the powder coated surface:

- Carefully remove any loose deposits with a wet sponge.
- Use a soft brush (non abrasive) or cloth and a mild household detergent solution to remove dust, salt and other deposits. Do not use steel wool, scrapers, scouring liquids or powders to remove deposits as these permanently scratch the coating surface.
- Rinse off with clean fresh water

PDAU0039



ALLEGION™

1800 098 094
info.au@allegion.com
ausloc.com